

S2-PLC-CCO

Solis PLC Central Controller

S2-PLC-CCO (CCO: Central Controller) is applied in PV systems to achieve power line communication. Power Line Communication is transmission of data over the AC Wires of the system.

Features:

- No need to lay communication cables, reducing construction costs and maintenance costs
- Strong anti-interference ability
- Support multi-terminal networking
- Stable network connection, real-time data transmission



S2-PLC-CCO

Intelligent Monitoring Solution - S2-PLC-CCO

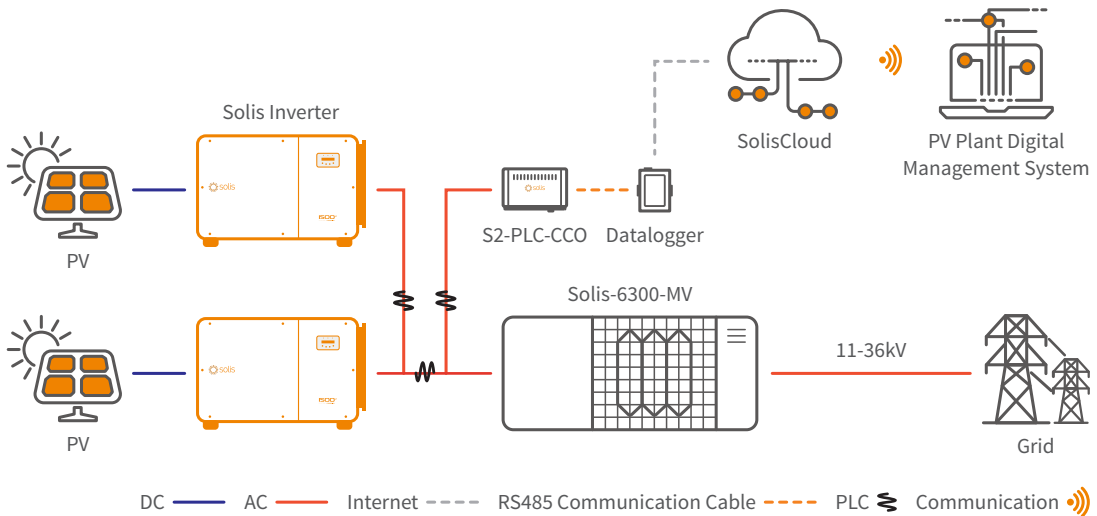

DATASHEET

S2-PLC-CCO

Models	S2-PLC-CCO
Communication	
Supported device type	Solis inverter
Number of connected inverters	≤80
Status indicator	4 LED Indicator Lights
Frequency band	2MHz-12MHz
Communication interface	4pin/RJ45/RS485
Debugging interface	Bluetooth
Baud rate	9600/19200/57600/115200
Electrical	
Input voltage (Power adapter)	12Vdc
Input current (Power adapter)	2Amax
AC port input line voltage	50-920 V, 50 Hz
Operating power consumption	<5 W
Environment	
Operating ambient temperature range	-40 ~ +70°C
Operating humidity	5%-95% relative humidity, non-condensing
Storage temperature	-45~+90°C
Storage humidity	5%-95% relative humidity, non-condensing
Max. operation altitude	4000 m
Protection degree	IP 20
Mechanical	
Dimensions (L*W*H)	255*165*45 mm
Installation method	Hanging ear mounting, rail mounting
Weight	750 g